



Thank you for purchasing our product. Before installing/operating the product, read the instructions carefully and retain them for future reference.

⚠ Attention!

- For installation, follow the steps described below. Any damage caused by wrong installation shall be imputed to the users.
- To avoid a short circuit from occurring, do not pull or modify the wires during installation.
- Do not disassemble or change any parts. Opening and disassembling this unit will void any warranty.
- Maintenance and repairs should be executed by our professionals only.

NOTE

- ⚠ Some procedures must be followed to avoid damages to the product.
- ⚠ **WARNING!** Certain procedures must be followed to avoid damages to yourself, to the vehicle or to others.

1 Accessories

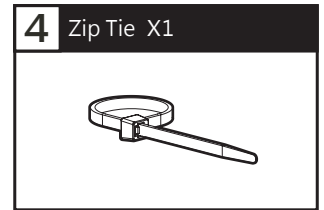
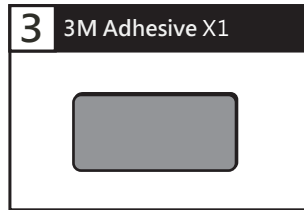
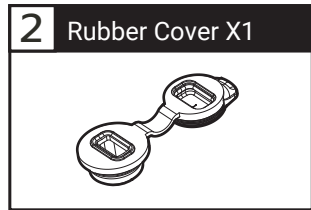
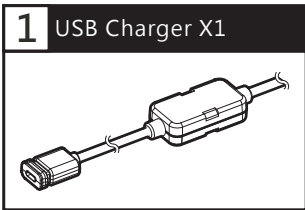

2 Specifications

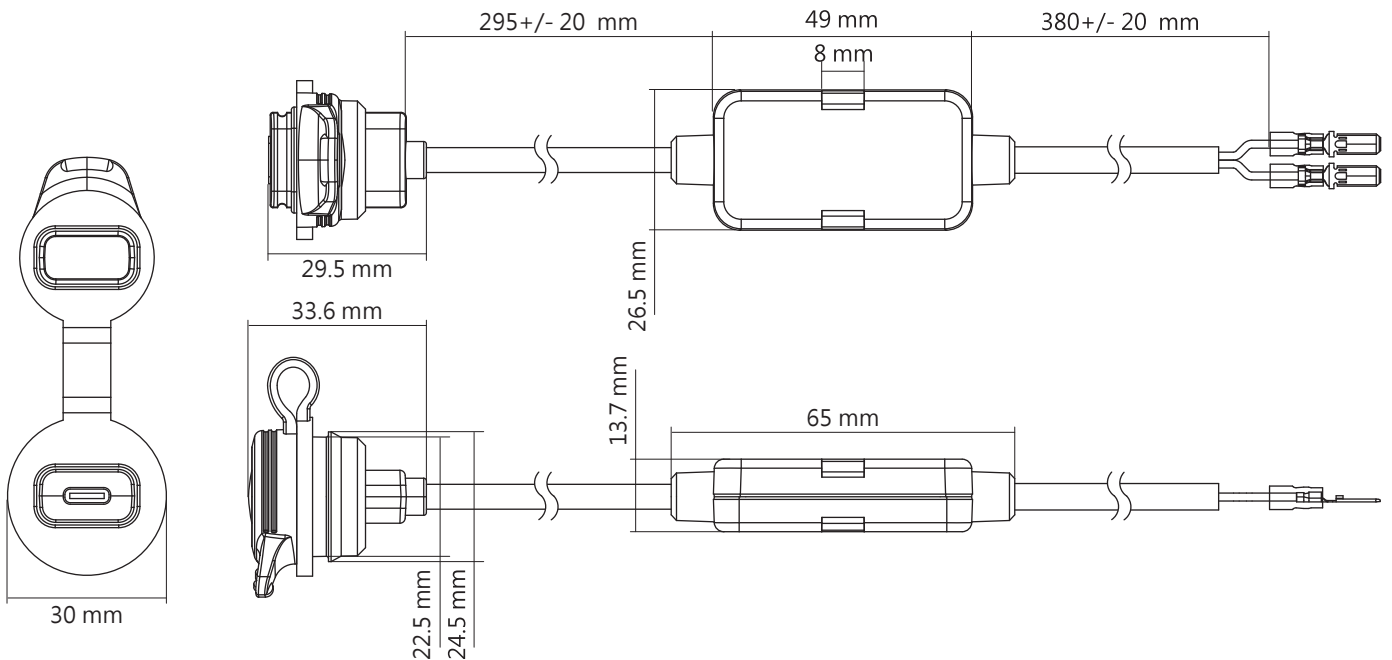

● USB Working Voltage	Voltage Range : DC 10 ~ 16 V Output specifications : DC 5V/3A 9V/2A(Requires protocol support when input power is over 10.5V) 12V/1.5A(Requires protocol support when input power is over 13.5V) Charging protocols : PD2.0/3.0 · PPS · APPLE 2.4A · QC4+ · AFC · FCP · SCP · PE2.0/1.1
● Effective temperature range	-20 ~ 80 °C
● IP Level	IP66
● Size	65 X 26.5 X 13.7 mm (Charger + rubber cover Ø30x33.6 mm)
● Weight	± 50 g

⚠ **Warning!** When washing the vehicle, DO NOT spray water or soap directly into the USB charger; this will damage the device and cause it to fail. When raining, DO NOT use the device and close the cover.

⚠ When the USB Charger is not in use, close the cover to avoid intrusion in the USB hub which may damage the device.

NOTE Design and specifications are subject to change without notice.

3 Installation Instructions

Follow the steps below during installation.

① Use proper tool to drill a hole on the correct position of the body case.

NOTE Required drilling size 23mm
($22.8\text{ mm} \leq X \leq 23.4\text{ mm}$).

⚠ Required body thickness $\leq 2.5\text{ mm}$, to prevent the rubber cover from failing to secure properly.

② USB Charger (Accessory 1)

③ Zip tie (Accessory 2)

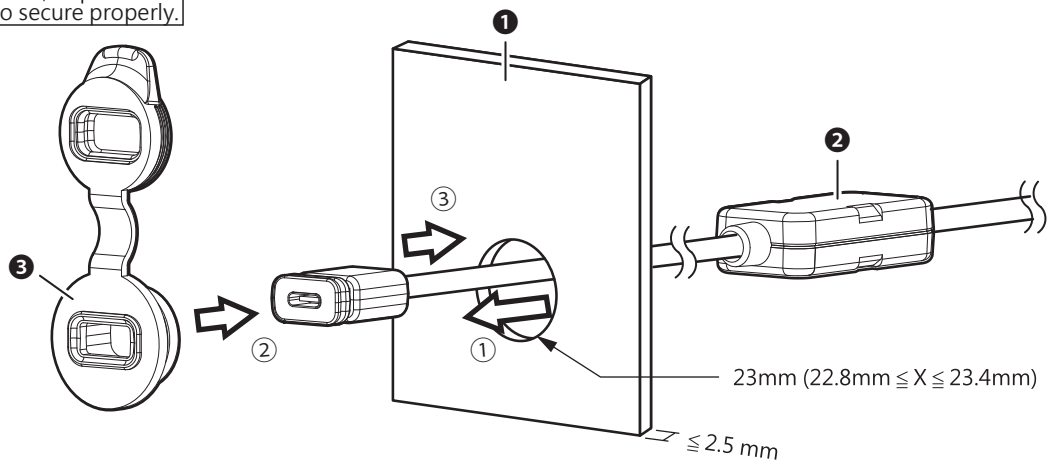

NOTE Secure the charger body inside the vehicle using adhesive (Accessory 3) or zip tie (Accessory 4), as needed.

NOTE Clean up the surface (including grease, water, and dust) where you want to place the Velcro before applying it. Also use your thumb to press the Velcro to ensure that it is in full contact with the surface to enhance the adhesion.

NOTE Total harness length is about 700 mm, so be aware during the hole drilling to prevent missing length on the harness.

4 Wiring installation instructions

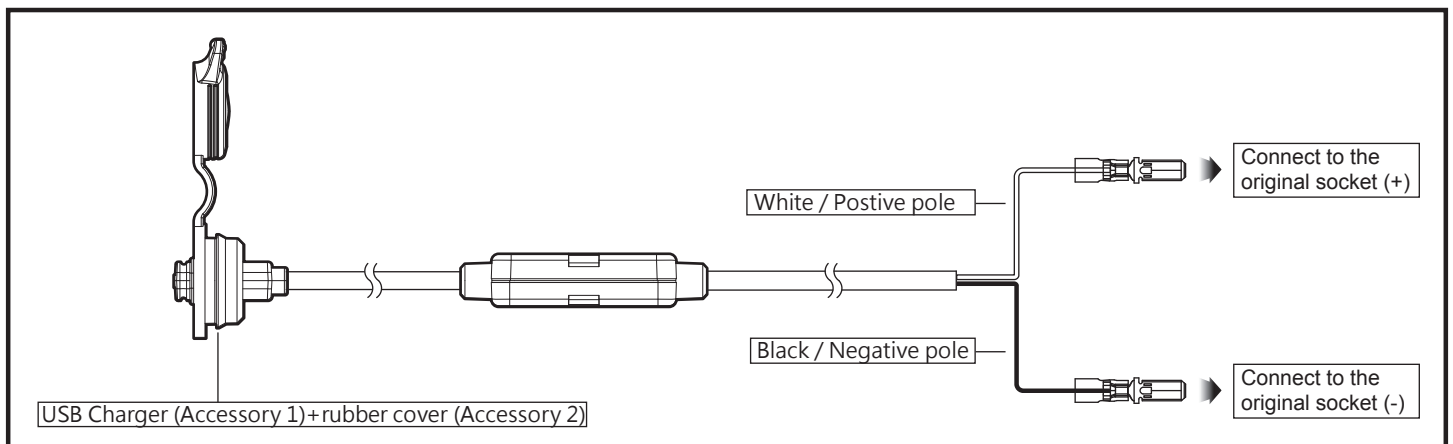

5 Troubleshooting

The following situations do not indicate malfunctions of the product. Check the following before taking it in for repair.

Trouble	Check item
No charging function or Indicator light not functioning.	<ul style="list-style-type: none"> ● There might be no power supply <ul style="list-style-type: none"> → Make sure the wires are connected. → Make sure the positive/negative poles are properly connected. → Battery malfunction or battery voltage lower than 10 V. → Check the wires of product and device.

※ If the problems still cannot be solved, contact our technical department for assistance.